

L. B. FOSTER COMPANY
 415 HOLIDAY DRIVE
 PITTSBURGH, PA. 15220

BRIDGE RAIL SYSTEM FOR:

FLORIDA

STYLE:	FABRICATED
TYPE:	3-LINE
MATERIAL:	ALUMINUM

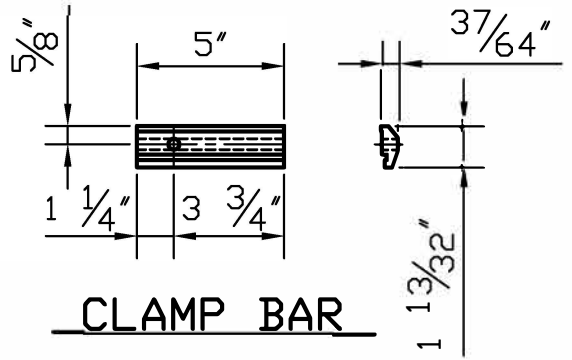
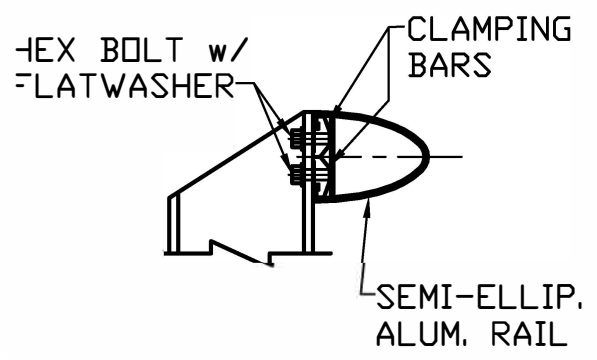
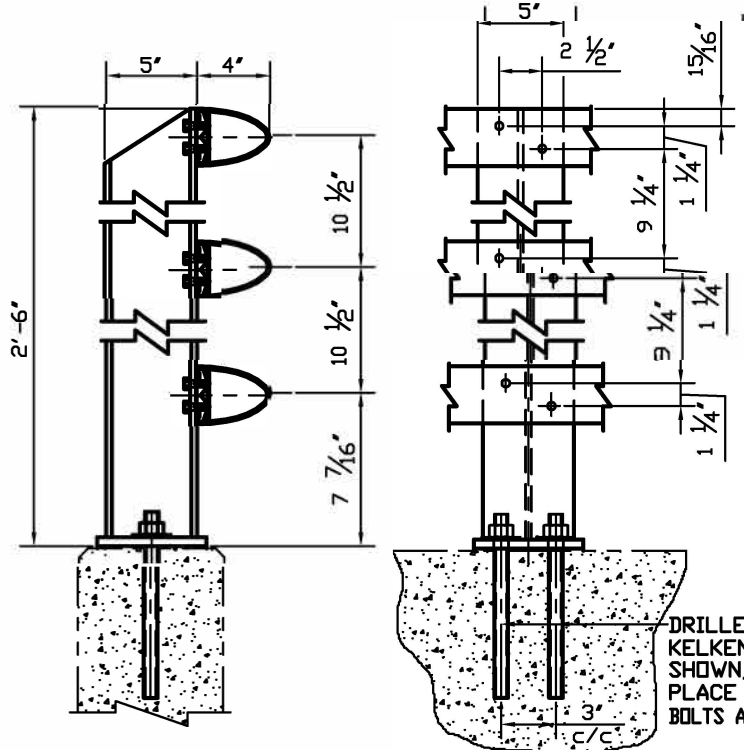

DRILLED-IN
 KELKEN ANCHORS
 SHOWN, CAST-IN-
 PLACE ANCHOR
 BOLTS ARE OPTIONAL.

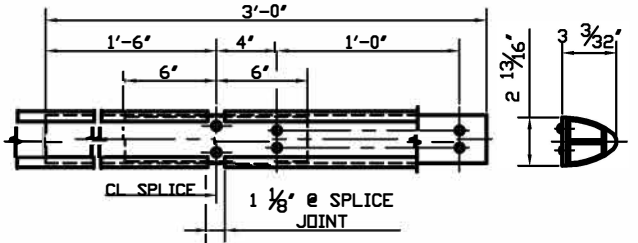
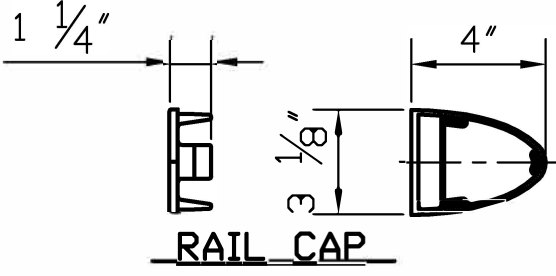

MATERIAL SPECIFICATIONS:

- RAILS, POSTS, SPLICES, CLAMP BARS & COVER PLATES:
 ALUMINUM A.S.T.M. B221, ALLOY 6061-T6
- POST BASE PLATES:
 ALUMINUM B209, ALLOY 6061-T6
- HEX HD. CAP SCREWS:
 A.S.T.M. A593, SERIES 300
- ALUMINUM WASHERS:
 A.S.T.M. B209, 2024-T4 ALCLAD
- STEEL ANCHOR RODS:
 A.S.T.M. A36, GALV. PER A153
- STEEL WASHERS:
 A.S.T.M. F436, GALV. PER A153
- STEEL HEX NUTS:
 A.S.T.M. A563, GRADE A, GALV. PER
- RESILIENT PADS:
 PER SECTION 932-2.1
- ALUMINUM END CAPS:
 A.S.T.M. B26, 356-F

