

MATERIAL SPECIFICATIONS:

- POST: ALUMINUM CAST PER A.S.T.M. M193 ALLOY A444-T4.
- RAIL: EXTRUDED ALUMINUM A.S.T.M. B221, ALLOY 6061-T6.
- RAIL SPLICE & CLAMP BAR: ALUMINUM A.S.T.M. B221, ALLOY 6061-T6.
- END CAP: ALUMINUM A.S.T.M. B26, ALLOY 356-F.
- RAIL HARDWARE: CAP SCREW A.S.T.M. F593. FLAT WASHERS A.S.T.M. A209.
- SPLICE HARDWARE: FILLISTER HEAD MACH. SCREW A.S.T.M. A276, ALLOY TY. 302.
- ANCHOR HARDWARE: THREADED ROD A.S.T.M. A36. HEX NUT A.S.T.M. A563 GR. A, GALVANIZED PER A153. FLAT WASHER A.S.T.M. F844, GALVANIZED PER A153.

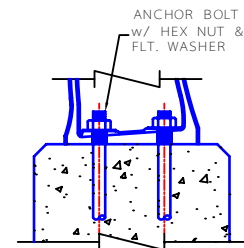
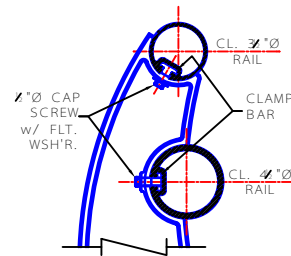
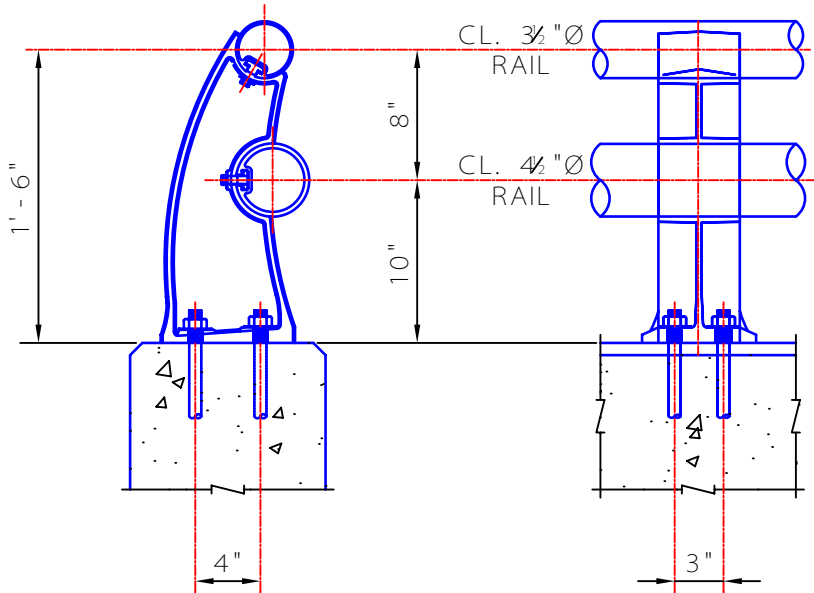

L. B. FOSTER COMPANY
 415 HOLIDAY DRIVE
 PITTSBURGH, PA. 15220

BRIDGE RAIL SYSTEM FOR:

OHIO

STYLE:

CAST

TYPE:

2-LINE

MATERIAL:

ALUMINUM

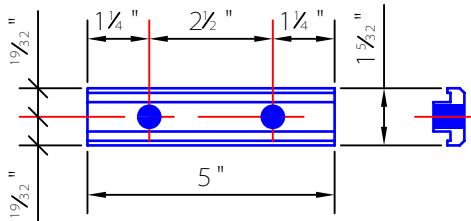
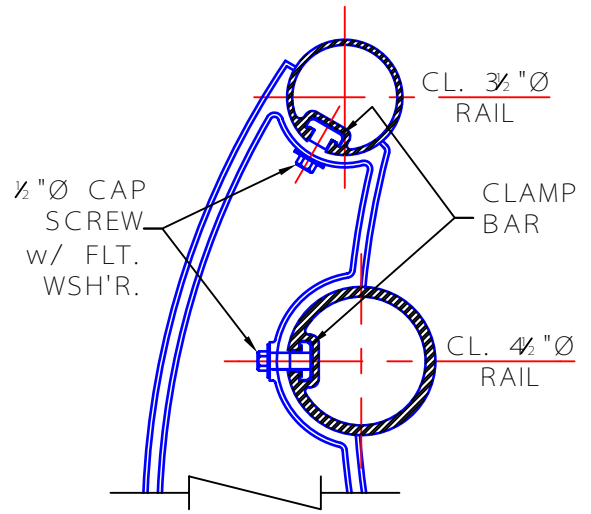
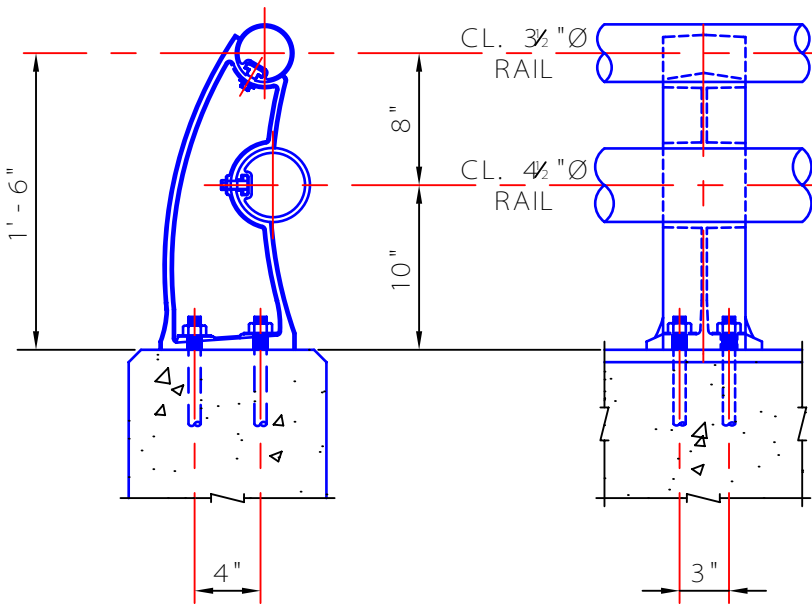

CLAMP BAR

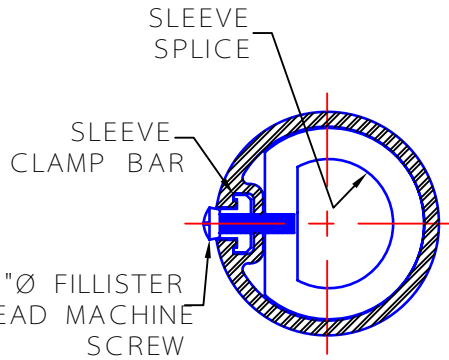

SECTION @ SPLICE

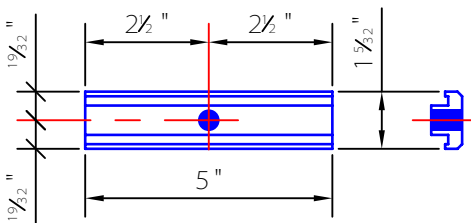
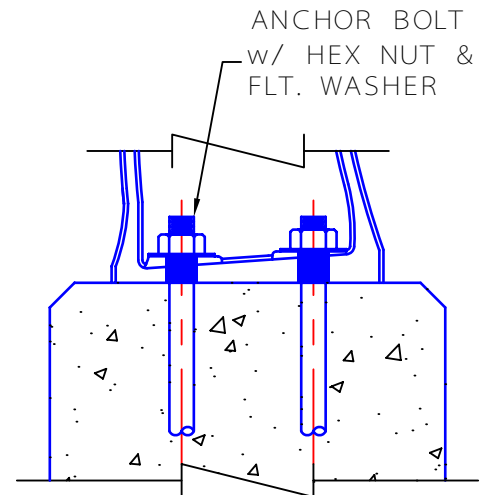

SLEEVE CLAMP BAR

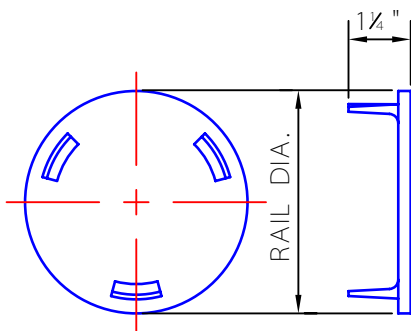

END CAP

MATERIAL SPECIFICATIONS:

POST: ALUMINUM CAST PER A.S.T.M. M193 ALLOY A444 - T4.

RAIL: EXTRUDED ALUMINUM A.S.T.M. B221, ALLOY 6061 - T6.

RAIL SPLICE & CLAMP BAR: ALUMINUM A.S.T.M. B221, ALLOY 6061 - T6.

END CAP: ALUMINUM A.S.T.M. B26, ALLOY 356 - F.

RAIL HARDWARE: CAP SCREW A.S.T.M. F593. FLAT WASHERS A.S.T.M. A209.

SPLICE HARDWARE: FILLISTER HEAD MACH. SCREW A.S.T.M. A276, ALLOY TY. 302.

ANCHOR HARDWARE: THREADED ROD A.S.T.M. A36. HEX NUT A.S.T.M. A563 GR. A, GALVANIZED PER A153. FLAT WASHER A.S.T.M. F844, GALVANIZED PER A153.