

L. B. FOSTER COMPANY
415 HOLIDAY DRIVE
PITTSBURGH, PA. 15220

BRIDGE RAIL SYSTEM FOR:

TENNESSEE

STYLE:

CAST

TYPE:

1-LINE

MATERIAL:

ALUMINUM

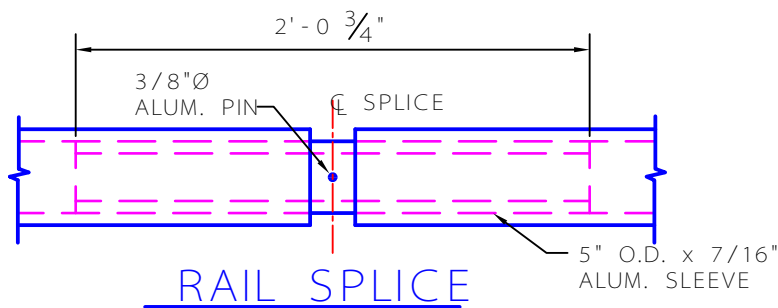
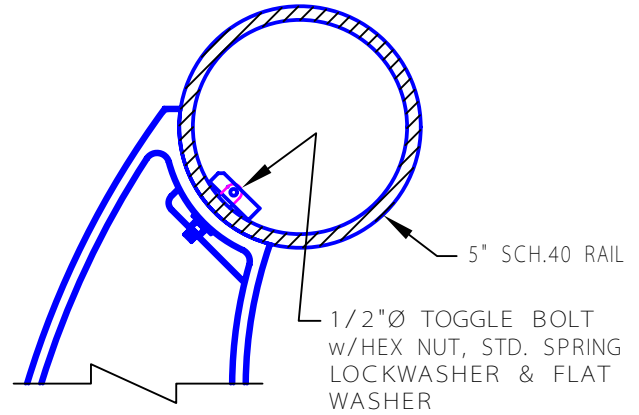
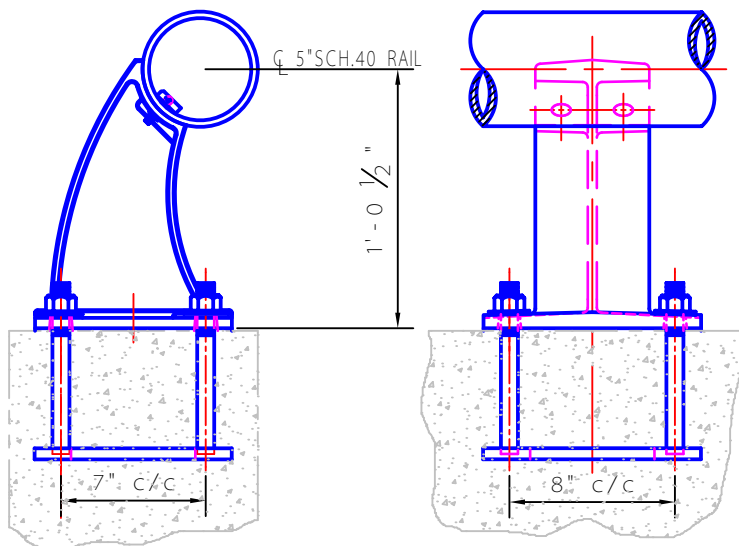

RAIL SPLICE

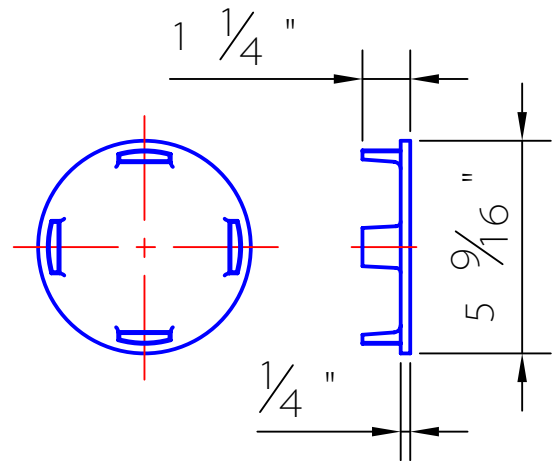

RAIL CAP

MATERIAL SPECIFICATIONS:

RAILS & SLEEVES:

ALUMINUM A.S.T.M. B429, ALLOY 6061-T6

CAST POSTS:

A.S.T.M. A444-T4

PINS:

A.S.T.M. B221, ALLOY 6061-T6

RIVETS:

ALUMINUM A331, ALLOY 4140 /41L40 C.R. STL.

TOGGLE:

A.S.T.M. A569, 1015 H.R. STL., PICKLED & OILED

TOGGLE BOLT:

A.S.T.M. A322, 1/2" -13 UNC, 414 /41L40 C.R. STL.,
HEAT TREATED RC 32-38 PER ASTM 354

WASHER:

A.S.T.M. A569, SAE 1020 H.R. STL. PLATE, BREAK
SHARP EDGES

NUT:

A.S.T.M. A311, 1/2" -13 UNC HEAVY. HEX 4140 /41L40
CR STL., HEAT TREATED PER ASTM A3256 or 7075-T6

ANCHOR RODS:

A.S.T.M. A36, GALV. PER A153

HEX NUTS (ANCHORS):

A.S.T.M. A563, GR.A, GALV. PER A153

WASHERS:

A.S.T.M. F844, GALV. PER A153

ANCHOR PLATES:

A.S.T.M. A36, PLAIN or GALVANIZE

ALUMINUM END CAPS:

A.S.T.M. B26, 356-F

NEOPRENE PAD:

NOMINAL DUROMETER HARDNESS OF 70±5

