

ALL PIPING INDICATED ON THIS SHEET IS NOT BY CXT

THIS DRAWING IS SUPPLIED FOR REFERENCE ONLY. PLEASE CONTACT CXT ENGINEERING DEPARTMENT FOR BUILDING SPECIFIC CONTROLLED DOCUMENTS PRIOR TO ANY FIELD WORK.

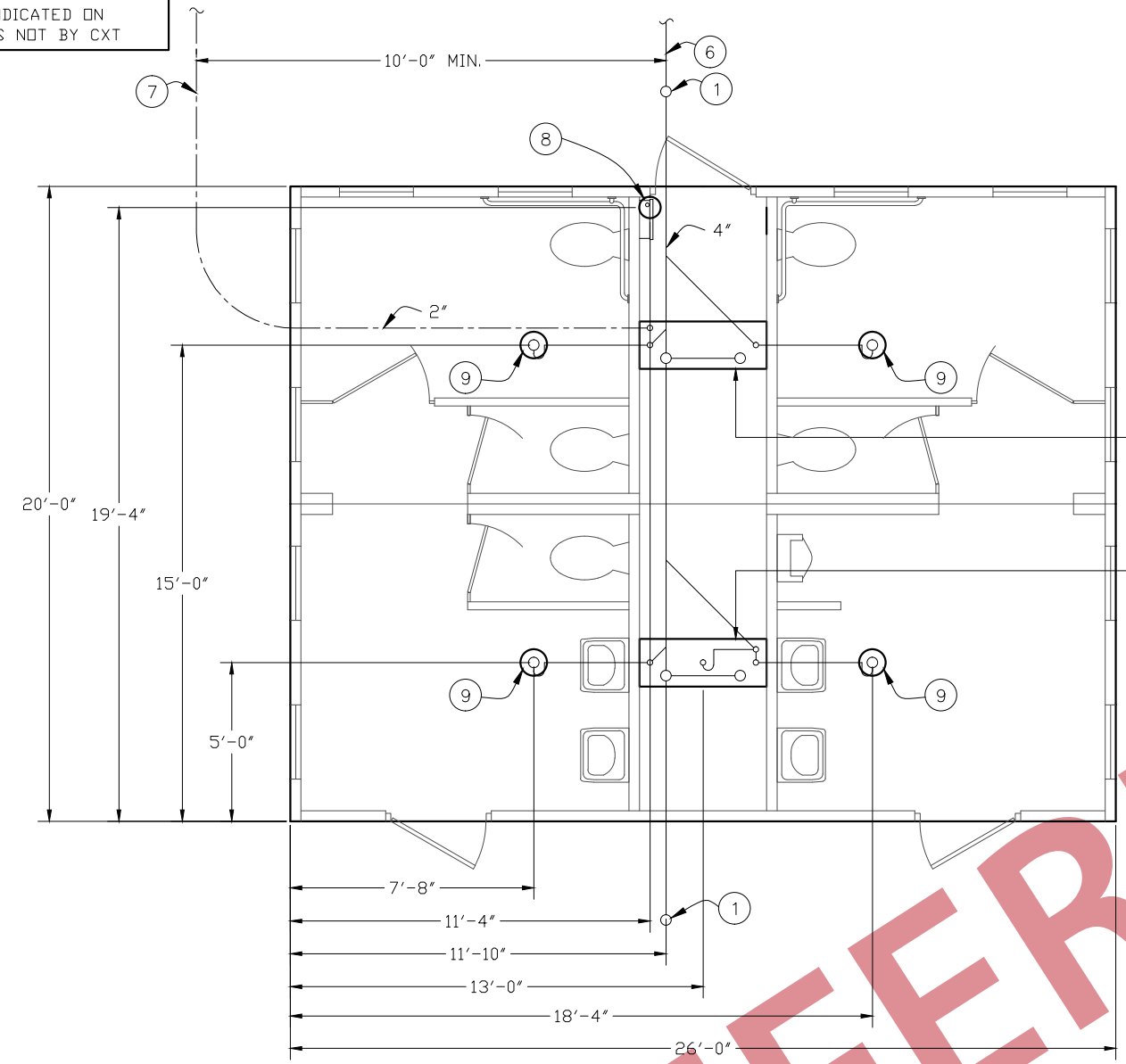

FLOOR DRAIN BLOCKOUTS & BELOW FLOOR PIPING

BELOW FLOOR PIPING - KEY NOTES

1. 4" CLEAN OUT TO GRADE.
2. 2" FLOOR DRAIN. FIELD INSTALLED TRAP PRIMER SYSTEM IF REQUIRED BY AUTHORITY HAVING JURISDICTION. (1'-6"x4'0" BLOCKOUT)
3. 2" VENT PIPES EXTENDED 12" ABOVE FINISHED FLOOR LEVEL, PROVIDE TEST PLUG. (1'-6"x4'0" BLOCKOUT)
4. 4" WASTE PIPE EXTENDED 12" ABOVE FINISHED FLOOR LEVEL, PROVIDE TEST PLUG. (1'-6"x4'0" BLOCKOUT)
5. 2" TYPE K ANNEALED "SOFT" COPPER WATER SERVICE EXTENDED 12" ABOVE FINISHED FLOOR LEVEL, PROVIDE CAP AT END. (1'-6"x4'0" BLOCKOUT)
6. 30" MIN. BURY, PROVIDE TRACER TAPE.
7. MIN. BURY PER LOCAL REQUIREMENTS TO PROTECT AGAINST FREEZING AND DAMAGE.
8. ELECTRICAL STUB UP, (8" DIA BLOCKOUT)
9. 2" FLOOR DRAIN. FIELD INSTALLED TRAP PRIMER SYSTEM IF REQUIRED BY AUTHORITY HAVING JURISDICTION. (10" DIA BLOCKOUT)

PIPING LEGEND

- 2" TYPE "K" ANNEALED "SOFT" COPPER WATER SERVICE
- BELOW FLOOR WASTE PIPING SCH 40 ABS TYPE DWV
- BELOW FLOOR VENT PIPING SCH 40 ABS TYPE DWV

FLOOR DRAIN DETAIL NOTES

- A. CAST-IN DRAIN HOUSING (10" INSIDE DIM - PROVIDED BY CXT)
- B. FIELD INSTALLED GROUT, SLOPE TO DRAIN (CXT PROVIDED-INSTALLATION NOT BY CXT)
- C. 2" WASTE PIPE - STUB UP 12" ABOVE GRADE (NOT BY CXT)
- D. TAPPED P-TRAP ADAPTER (NOT BY CXT)
- E. P-TRAP ASSEMBLY (NOT BY CXT)
- F. 1/2" O.D. COPPER TRAP PRIMER LINE IF REQUIRED BY AHJ (NOT BY CXT)
- G. 2" FLOOR DRAIN VENT RISER - STUB UP 12" ABOVE GRADE (NOT BY CXT)
- H. TRAP PRIMER MANIFOLD (PRE-PLUMBED AND INSTALLED BY CXT)
- I. 1/2" SHUT OFF VALVE (PRE-PLUMBED AND INSTALLED BY CXT)

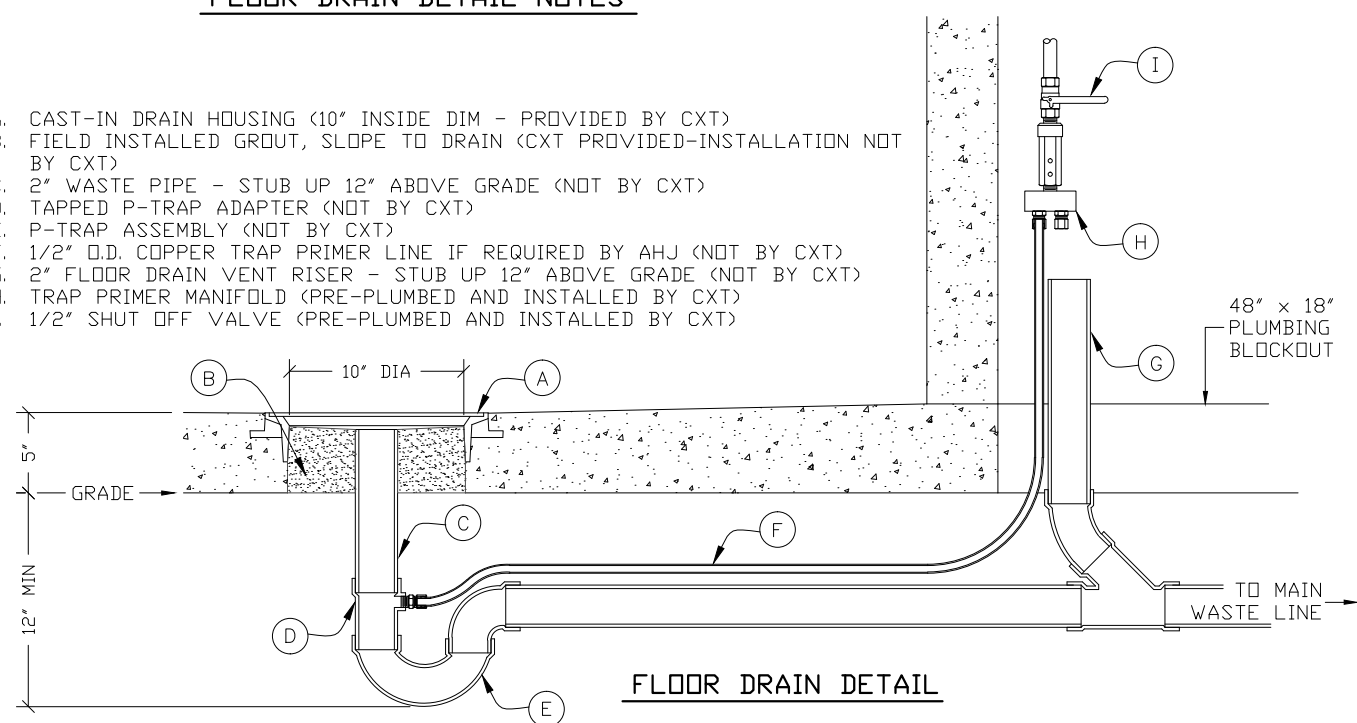

FLOOR DRAIN DETAIL

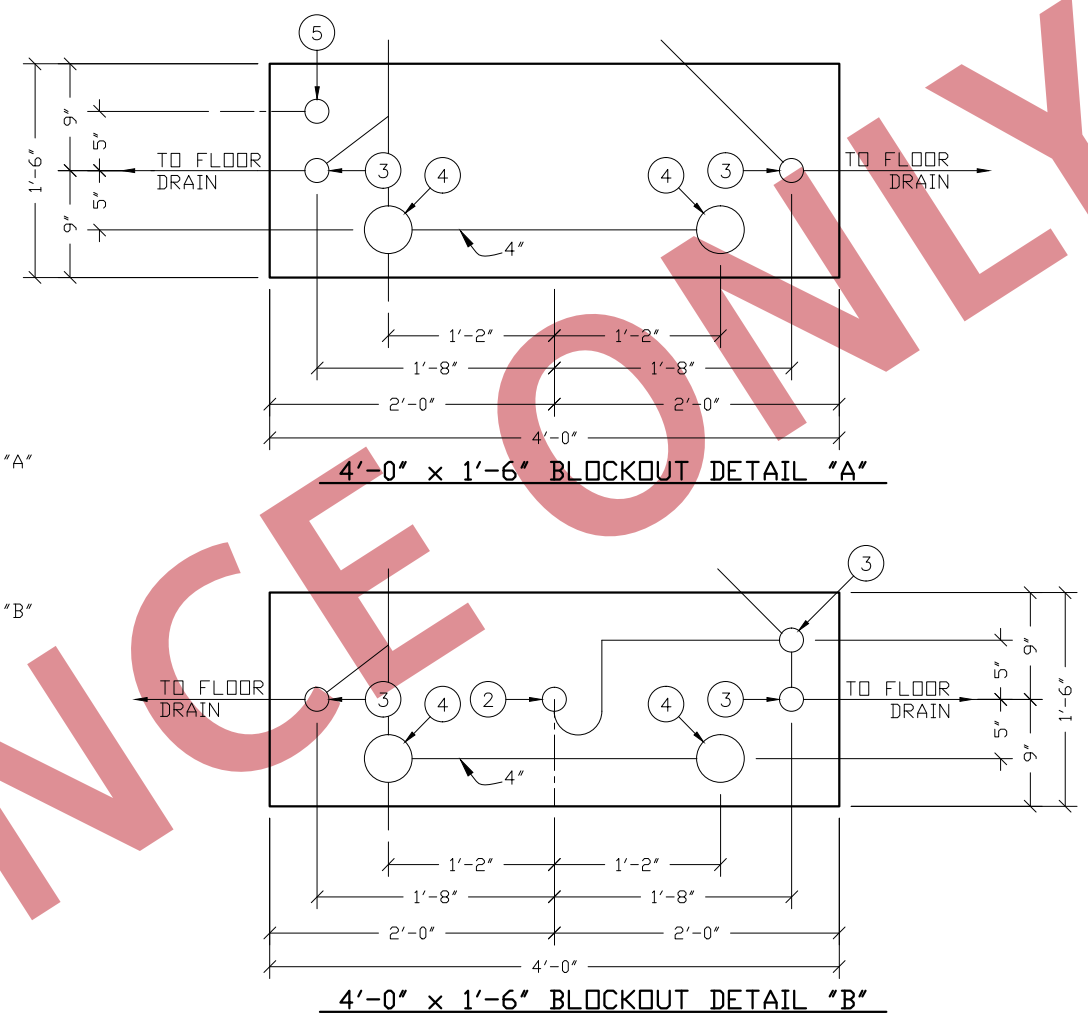

SEE 4'-0" x 1'-6" BLOCKOUT DETAIL "A"

SEE 4'-0" x 1'-6" BLOCKOUT DETAIL "B"

4'-0" x 1'-6" BLOCKOUT DETAIL "A"

4'-0" x 1'-6" BLOCKOUT DETAIL "B"



6701 E. Flamingo Ave, Bldg 300, Nampa ID 83687
901 N. Waco St, Hillsboro TX 76645
326 Waverly Rd, Williamstown WV 26187

PROJECT TITLE
TAOS
CXT STANDARD BUILDING

NOTICE
The information contained herein is proprietary and the exclusive property of CXT Incorporated. The information may only be used by the original recipient for the purpose intended. Reproduction or distribution of this information is strictly prohibited without the prior written consent of CXT Incorporated. By allowing use of this information, CXT Incorporated grants no warranty, express or implied, including a warranty of merchantability or of fitness for a particular purpose.

REV.	DESCRIPTION	APPROVAL	DATE
SCALE	3/16" = 1'-0"	DATE	04-30-16
DRAWN	FILE NO.	FOR REF	
CHECKED	PLOT	64	

FLOOR DRAIN LOCATION & BELOW FLOOR PIPING

DWG NO.	SHEET	REV.
---------	-------	------