

PLAN VIEW

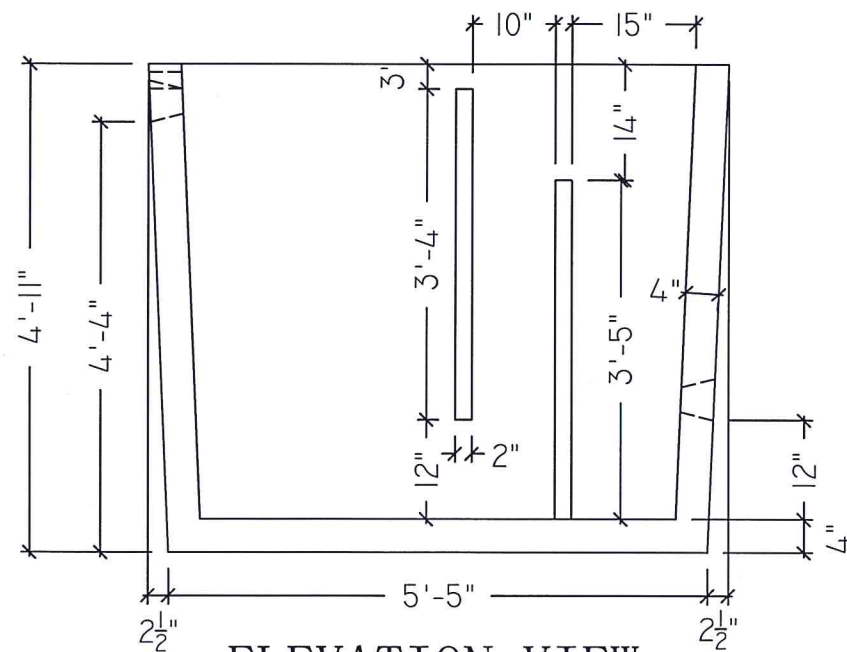

ELEVATION VIEW

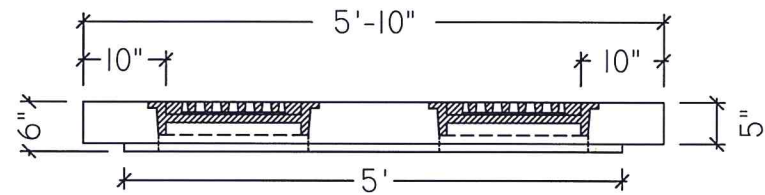
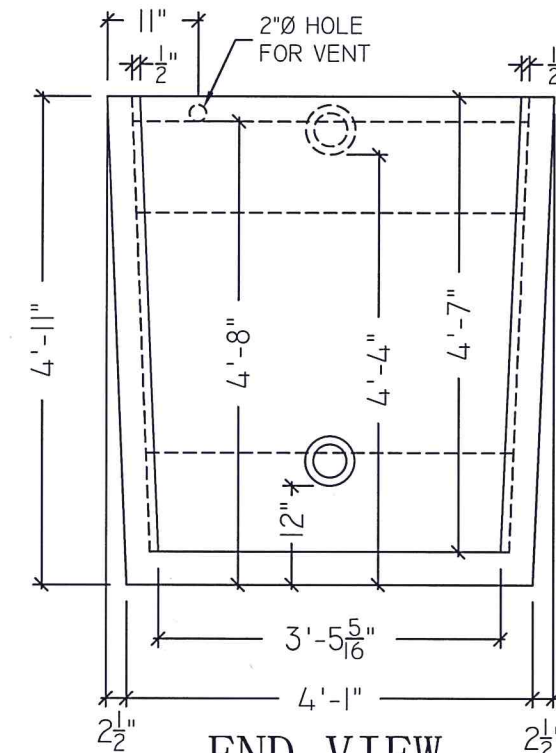
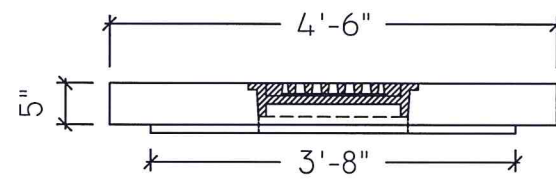

END VIEW

NOTES:

1. 28-DAY COMPRESSION STRENGTH = 5000 PSI
2. ALL REINFORCING STEEL IS TO BE UNCOATED GRADE 60.
3. MINIMUM #3 BAR LAP IS NOT TO BE LESS THAN 1'-6".
4. BOTH DIVIDER WALLS TO BE REINFORCED WITH #3 REBAR OR EQUIVALENT.

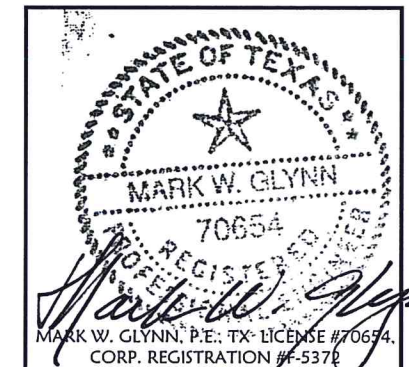

- 500 Gallon Grease Trap Structures:
1. CONCRETE UNDERGROUND GREASE TRAP DESIGN IS IN ACCORDANCE WITH AC1318-11
 2. CONCRETE GREASE TRAPS ARE DESIGNED SUCH THAT THE TOP OF THE CAP STRUCTURE IS LEVEL OR ABOVE GRADE.
 3. DESIGN IS BASED ON HL-93 TRAFFIC LOADING AND CONSIDERS THE TOP CAP TO BE INDEPENDENT OF THE REST OF THE STRUCTURE SUCH THAT NO "NEGATIVE" MOMENTS ARE GENERATED AT THE CAP TO WALL INTERFACE.

CARR CONCRETE GREASE TRAPS
- HILLSBORO, TX
GLYNN GEOTECHNICAL ENGINEERING (GGE) HAS PREPARED DESIGN CALCULATIONS FOR, AND HAS REVIEWED AND ACKNOWLEDGES THE CONCRETE GREASE STRUCTURE & DETAILS PREPARED BY CARR CONCRETE AS SHOWN ON THIS SHOP DRAWING.
GGE PROJ. No. 16-1108
DATE: September 2, 2016



GLYNN GEOTECHNICAL ENGINEERING
415 S. TRANSIT STREET
LOCKPORT, NEW YORK 14094
www.glynngroup.com
VOICE (716) 625-6933 / FAX (716) 625-6983

APPROX WEIGHT: 8,400#



PHONE: 254-296-6100
FAX: 254-296-6101
901 N. HIGHWAY 77
HILLSBORO, TX - 76645

CXT, INC. - HILLSBORO

PROJECT #:
HILLSBORO, TX
500 GALLON GREASE TRAP

FILE# DRAWN BY: ETL DATE: 8/16/16

DWG. NO.	REV	DESCRIPTION	DATE
1			
OF			
3			