

LID VIEW

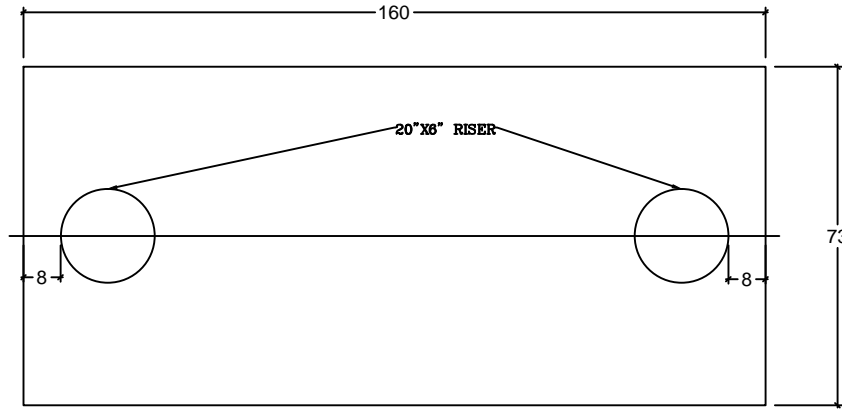

LID SIDE VIEW

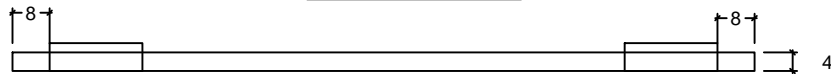

SIDE VIEW

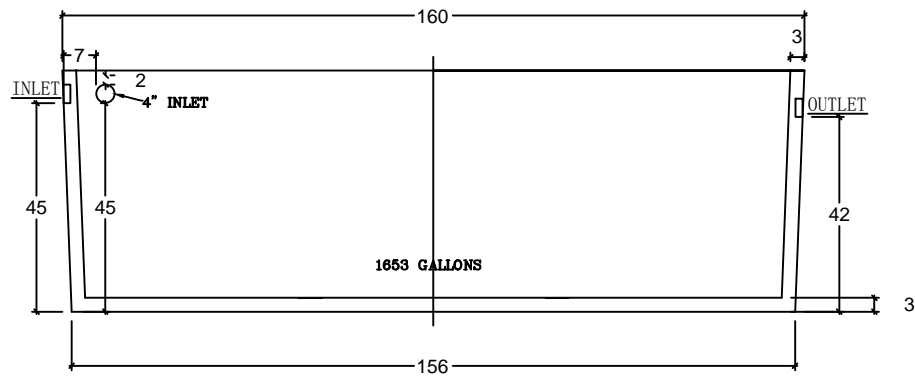

NOTES:

1. 28-DAY COMPRESSION STRENGTH = 5000 psi
2. ALL REINFORCING STEEL IS TO BE UNCOATED GRADE 60 .
3. MINIMUM #3 BAR LAP IS NOT LESS THAN 1'-6"
4. 4" LID THICKNESS REINFORCED WITH #4 REBAR

END VIEW

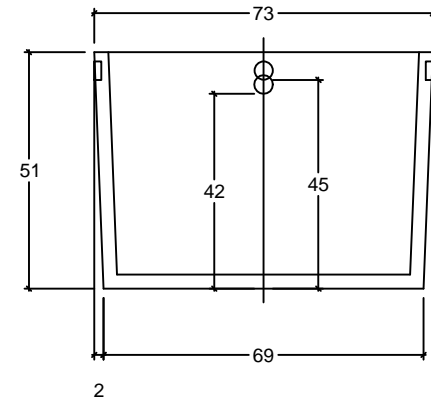

PHONE:
254.296.6115
ADDRESS:
901 N. HWY 77
HILLSBORO, TX 76645

CXT, INC. HILLSBORO

1500-CN TANK

DRAWN BY: MR DATE: 9/7/18 CHECKED BY: CHECKED DATE:

DWG. NO.	REV	DESCRIPTION	DATE
OF			
REV BY:		ADDED SIDE INLETS	

LID VIEW

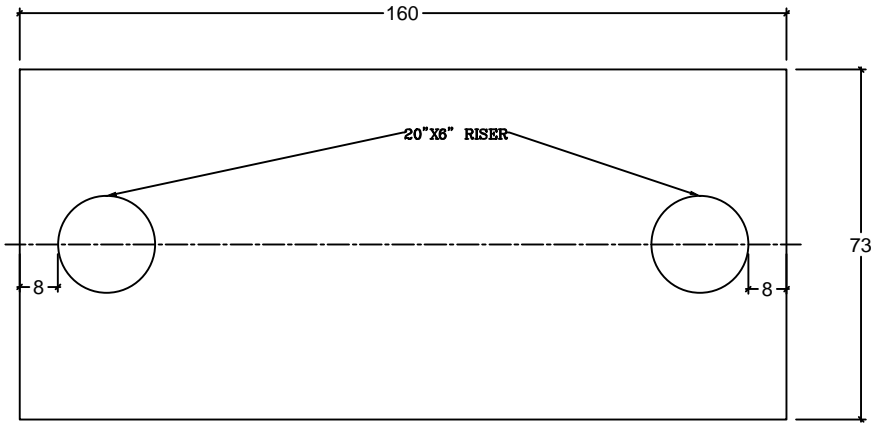

LID SIDE VIEW

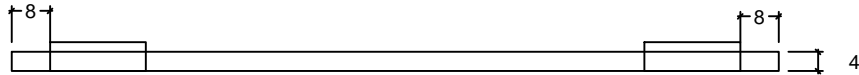

SIDE VIEW

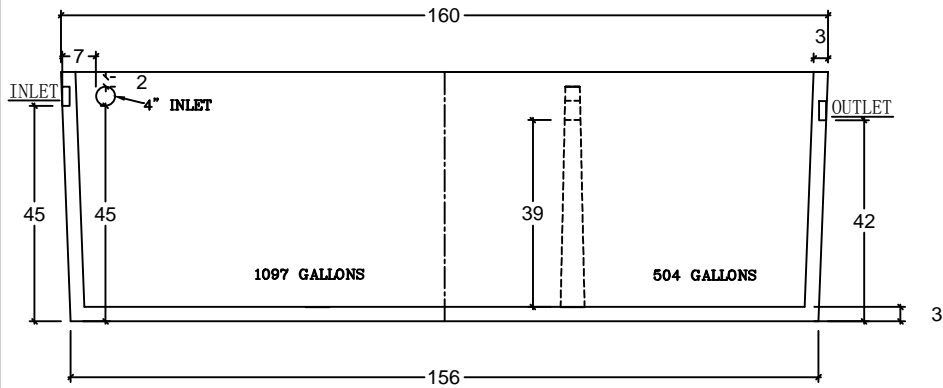

NOTES:

1. 28-DAY COMPRESSION STRENGTH = 5000 psi
2. ALL REINFORCING STEEL IS TO BE UNCOATED GRADE 60 .
3. MINIMUM #3 BAR LAP IS NOT LESS THAN 1'-6"
4. 4" LID THICKNESS REINFORCED WITH #4 REBAR

END VIEW

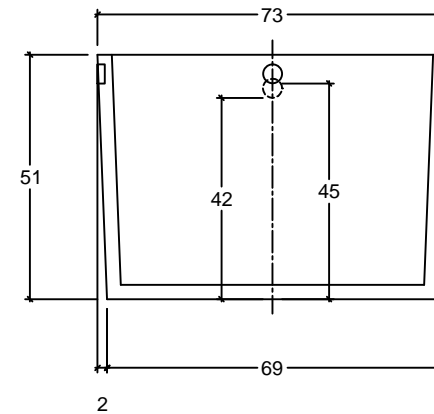

PHONE:
254.296.6115
ADDRESS:
901 N. HWY 77
HILLSBORO, TX 76645

CXT, INC. HILLSBORO

1500-2CN TANK

DRAWN BY: MR DATE: 9/7/18 CHECKED BY: CHECKED DATE:

DWG. NO.	REV	DESCRIPTION	DATE
OF			
REV BY:	T	ADDED SIDE INLETS	4/11/19

LID VIEW

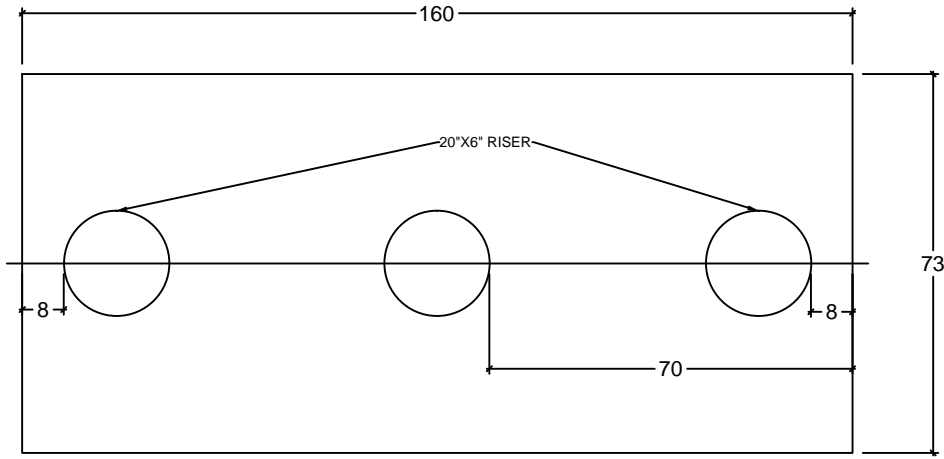

LID SIDE VIEW



SIDE VIEW

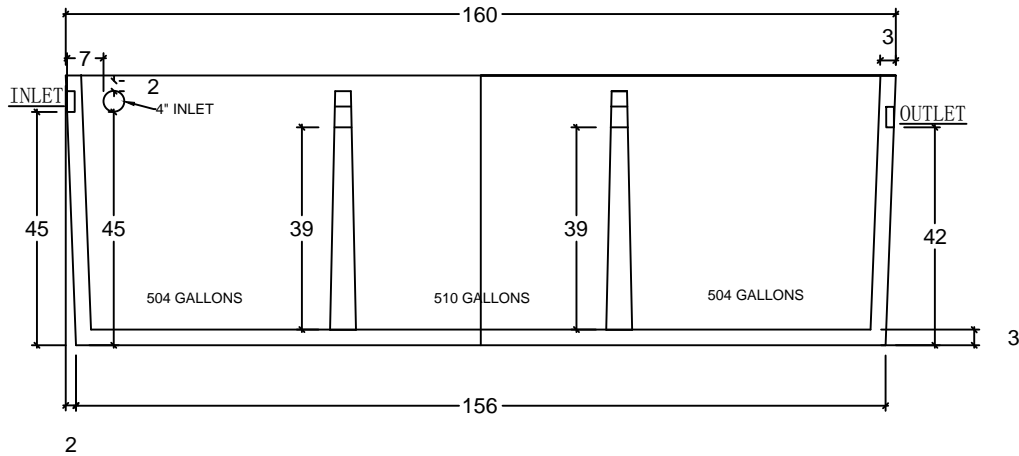

NOTES:

1. 28-DAY COMPRESSION STRENGTH = 5000 psi
2. ALL REINFORCING STEEL IS TO BE UNCOATED GRADE 60 .
3. MINIMUM #3 BAR LAP IS NOT LESS THAN 1'-6"
4. 4" LID THICKNESS REINFORCED WITH #4 REBAR

END VIEW

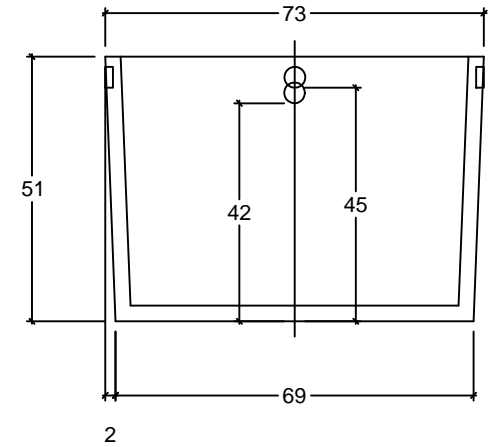

PHONE:
254.296.6115
ADDRESS:
901 N. HWY 77
HILLSBORO, TX 76645

CXT, INC. HILLSBORO

1500-3CN TANK

DRAWN BY: MR DATE: 9/7/18 CHECKED BY: CHECKED DATE:

DWG. NO.	REV	DESCRIPTION	DATE
OF			
REV BY:	1	ADDED SIDE INLETS	4/11/19